

LETTER

Numerical Analysis of Wall Material Effect on Indoor MIMO Channel Capacity

Xiao Peng YANG^{†a)}, Student Member, Qiang CHEN[†], Member, and Kunio SAWAYA[†], Fellow

SUMMARY Effects of wall material on the channel capacity of an indoor multiple input multiple output (MIMO) system are investigated using a hybrid technique of the method of moments (MoM) and the finite difference time domain (FDTD) method with consideration of the Ricean K factor and the effective degrees of freedom (EDOF) of multiple paths.

key words: MIMO, channel capacity, indoor channel, hybrid method, Ricean K factor, effective degrees of freedom (EDOF)

1. Introduction

Recently, MIMO system, which uses multiple antennas at both the transmitter and the receiver, for indoor wireless communications has attracted considerable research attentions [1]–[7]. The Monte-Carlo method [1], the ray tracing method [2], the FDTD method [3], [4], and the experimental investigations [5], [6] have been used to analyze the channel capacity of MIMO system. Among these approaches, it has been pointed out that the FDTD method is a highly effective method to investigate the indoor MIMO channel including almost arbitrary scatterers. However, the CPU time of FDTD is usually unacceptable when the spatial statistics of received signals for MIMO channel capacity are required. In this paper, a hybrid technique of the MoM and the FDTD method is used to analyze the indoor MIMO channel capacity, which can give more accurate spatial statistical results and save CPU time significantly [8], [9].

In evaluating the indoor MIMO channel capacity, the wall effects should be considered. Some researches on the wall effects have been carried out by using the FDTD method [3], [4], but they were limited only to two dimensional (2-D) analysis. The three dimensional (3-D) indoor model has been analyzed by using the array decomposition fast multipole method (AD-FMM) [7]. However, the effects of wall material have not been investigated sufficiently. In this paper, the effects of wall material on the indoor MIMO channel capacity are investigated with consideration of the Ricean K factor and the EDOF of multiple paths based on the channel transfer matrices obtained by the hybrid technique of the MoM and the FDTD method.

2. Hybrid Technique and Analysis Model

In the hybrid technique, the FDTD method is used to analyze the transmitting array antennas and the propagation channel, and the MoM is applied to analyze the receiving array elements which move randomly in the local receiving area in order to obtain the spatial statistical characteristics. The electric field of the whole region is calculated by the FDTD method except for the receiving array antennas. The electric field in the receiving area is stored and then used as the incident electric field on the receiving array elements which are analyzed by the MoM. In the MoM analysis, the receiving element is divided into M dipole segments for sub-domain analysis. The piecewise sinusoidal function is used as the basis function and weighing functions, which is denoted by

$$f_m(\tau) = w_m(\tau) = \frac{\sin k_0(\Delta\tau - |\tau|)}{\sin(k_0\Delta\tau)}, \quad m = 1, 2, \dots, M. \quad (1)$$

where k_0 is the wave number in free space and $\Delta\tau$ is a half length of the divided dipole segments [10]. The voltage of m th segment of the receiving element is calculated by

$$V_m = \int w_m(\tau) \cdot E_m(\tau) d\tau \quad (2)$$

where $E_m(\tau)$ is the incident electric field on the m th segment of receiving antenna evaluated by the FDTD method. According to the voltage matrix calculated by Eq. (2) and the mutual impedance matrix of the receiving array antennas calculated by Richmond's moment [11], the current distribution on the receiving antenna element and the received signal are obtained. Based on the transmitted and received voltages, the channel transfer matrix H of MIMO system can be evaluated.

In our simulation, a single user to single user narrow band 2×2 MIMO system with uniform power scheme is considered. In order to investigate the wall effect, only the wall is considered and the other scatterers inside the room are not included in the analysis model, which is shown in Fig. 1. The whole region is analyzed by the FDTD firstly and the electric fields in the receiving area is stored and then used as the incident fields for the MoM analysis to obtain the received signals.

The length, width and height of analysis region are

Manuscript received March 2, 2006.

Manuscript revised April 25, 2006.

[†]The author is with the Department of Electrical and Communication Engineering, Graduate School of Engineering, Tohoku University, Sendai-shi, 980-8579 Japan.

a) E-mail: yang@ecei.tohoku.ac.jp

DOI: 10.1093/ietcom/e89-b.10.2949

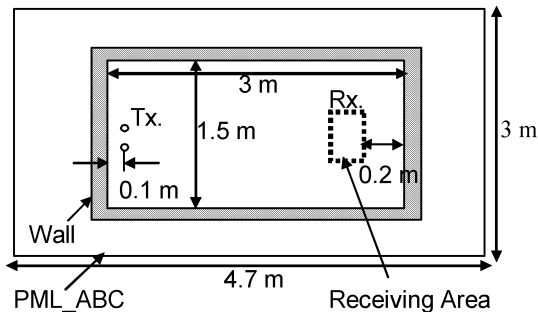

Fig. 1 Configuration of analysis model.

4.7 m, 3 m and 3 m, respectively. The receiving antenna array moves randomly in the local receiving area (0.4 m × 0.2 m × 0.2 m). The whole analysis region is divided into 346 × 211 × 211 Yee cells with the 8-layer perfectly matched (PML) absorbing boundary. The total transmitted power is constrained to -30 dBm. Only the additive white noise of -93.98 dBm is considered on each output of the receiving antenna elements. The operation frequency is 800 MHz, and the vertical half wavelength dipole antennas are used for both the transmitting and the receiving antennas.

3. Ricean K Factor and EDOF

The Ricean K factor and the EDOF are useful parameters to analyze the multiple paths for MIMO system. When the electric field distribution is known, the Ricean K factor can be calculated by [6]

$$K = \frac{\sqrt{1-\gamma}}{1-\sqrt{1-\gamma}}, \quad \gamma = \frac{\sigma_r^2(A^2)}{E[A^2]} \tag{3}$$

where γ is the ratio of the variance of the power to its mean, $E[\cdot]$ is the expectation and A^2 is the power.

EDOF is the number of effective parallel sub-channels which are formed by the MIMO wireless channel and is calculated by

$$EDOF = \sum_{i=1}^n \lambda_i^2 / \max[\lambda_i^2] \tag{4}$$

where λ_i is the i th eigenvalue of MIMO channel transfer matrix. EDOF is a real number larger than unit but less than the minimum value of transmitting and receiving array antennas. The effect of path loss is not included in this parameter [4].

4. Numerical Results

The effects of three kinds of practical material of the walls, i.e. the wooden wall, the concrete wall, and the reinforced concrete wall, are investigated by using the hybrid technique. The parameters of the wooden wall and concrete wall are listed in Table 1. The reinforced concrete wall is formed by deploying 6 cubical metallic pillars

Table 1 Parameters of wooden wall and concrete wall.

	Relative Permittivity	Conductivity [S/m]	Thickness [m]
Wooden	3	0	0.1
Concrete	6.25	0.0814	0.2

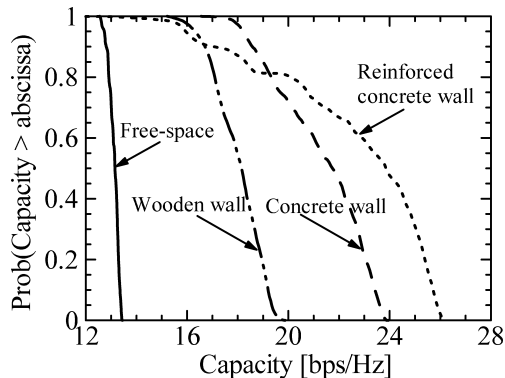

Fig. 2 CCDF of indoor MIMO channel capacity for three kinds of material of wall when total transmitted power is constrained to -30 dBm.

Table 2 Average values of Ricean K factor, EDOF and received power for three kinds of wall material.

	Received Power [dBm]	EDOF	Ricean K factor [dB]
Free Space	-63.7	1.0001	∞
Wooden wall	-64.9	1.2270	8.62
Concrete wall	-59.3	1.1787	5.32
Reinforced Concrete wall	-56.4	1.1894	3.08

(0.2 m × 0.2 m × 1.9 m) in the concrete wall.

The complementary cumulative distribution functions (CCDF) of the MIMO channel capacity in the local receiving area for different walls are calculated and shown in Fig. 2. The average values of Ricean K factor, EDOF and received power on each receiving antenna are listed in Table 2. The results of the free space are also calculated and shown in Fig. 2 and Table 2 for comparison. It is found that the MIMO channel capacity is improved by the presence of the walls, and the reinforced concrete wall brings the highest capacity because the received power is the highest. Although the wooden wall brings the lowest received power, the EDOF is the highest so that the capacity is higher than that in free space. Therefore, the received power and EDOF should be considered together to estimate the MIMO channel capacity reasonably. According to the change of the Ricean K factor in the simulations, it is found that the MIMO channel capacity becomes higher when the Ricean K factor becomes smaller. These numerical results imply that the Ricean K factor is also an appropriate parameter to estimate the MIMO channel capacity.

In some researches on the analysis of the MIMO capacity, the channel normalization is applied so that the path loss is excluded in the analysis. The Frobenius norm given by

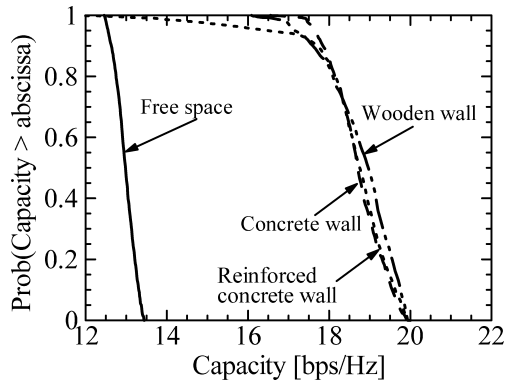

Fig. 3 CCDF of indoor MIMO channel capacity for three kinds of wall material when the channel normalization is applied and the received SNR is assumed to be 30 dB.

$$\sum_{i=1}^{N_t} \sum_{j=1}^{N_r} |Bh_{ij}|^2 = N_t N_r \quad (5)$$

is used to make the power transfer between a single transmitting antenna and a single receiving antenna be unity [1]–[7], where h_{ij} is the elements of the MIMO channel transfer matrix, B is a normalization constant, N_t and N_r are the number of transmitting and receiving array elements. Based on this normalization, the CCDFs of the indoor MIMO channel capacity for the wall material are investigated when the received signal noise ratio (SNR) on the each receiving antenna branch is constrained to 30 dB, and shown in Fig. 3. It is also found that the MIMO channel capacity is improved due to the presence of the wall. However, the MIMO channel capacity is almost independent of wall material. This result is different from that without channel normalization. Because the MIMO channel capacity is dependent on both path loss and effective multiple paths, it seems that the wall material effect is very small on the multiple path effect. Although the wall material effect is not significant, it is found from Fig. 3 and Table 2 that EDOF for different wall material has a high correlation with the MIMO channel capacity. Therefore, when the channel normalization is applied, EDOF is a proper parameter instead of Ricean K factor to investigate the MIMO channel capacity.

5. Conclusions

The effects of wall material on the indoor MIMO channel capacity have been investigated by using a hybrid technique of the MoM and the FDTD method. It is found that the MIMO channel capacity can be greatly improved due to the presence of the walls. When the total transmitted power is fixed, the MIMO channel capacity is affected by the wall material, and the Ricean K factor is an appropriate param-

eter to analyze the indoor MIMO channel capacity. On other hand, when the channel normalization is applied, the effects of wall material seem to be small and EDOF is a proper parameter to analyze the indoor MIMO channel capacity. It should be noted that the wall effects have been investigated based on a certain thickness of the wall in the present research, but the thickness could also bring some effects on the indoor MIMO capacity. A more practical analysis model reflecting effects of the wall material, thickness, and structure is under investigation.

Acknowledgement

This work was supported by Tohoku University Electro-Related Departments 21st Century COE Program. Part of the numerical results in this research were obtained using supercomputing resources at Information Synergy Center, Tohoku University.

References

- [1] K. Yu and B. Ottersten, "Models for MIMO propagation channels: A review," *Wirel. Commun. Mob. Comput.*, vol.2, no.7, pp.653–666, Nov. 2002.
- [2] M.F. Iskander and Z. Yun, "Advances in propagation modeling of wireless communications environments and systems," *IEICE Trans. Electron.*, vol.E87-C, no.9, pp.1441–1448, Sept. 2004.
- [3] Z. Yun, M.F. Iskander, and Z. Zhang, "Complex-wall effect on propagation characteristics and MIMO capacities for an indoor wireless communication environment," *IEEE Trans. Antennas Propag.*, vol.52, no.4, pp.914–922, April 2004.
- [4] J.W. Wallace and M.A. Jensen, "MIMO capacity variation with SNR and multipath richness from full-wave indoor FDTD simulations," *Proc. IEEE Antennas and Propagat. Soc. Int. Symp.*, vol.2, pp.523–526, June 2003.
- [5] J.W. Wallace, M.A. Jensen, A.L. Swindlehurst, and B.D. Jeffs, "Experimental characterization of the MIMO wireless channels: Data acquisition and analysis," *IEEE Trans. Wirel. Commun.*, vol.2, no.2, pp.335–343, March 2003.
- [6] Z.W. Tang and A.S. Mohan, "Experimental investigation of indoor MIMO Ricean channel capacity," *IEEE Antennas Wirel. Propag. Lett.*, vol.4, pp.55–58, 2005.
- [7] C.P. Lim and J.H. Volakis, "On the capacity for MIMO systems in Ricean fading indoor environments," *Proc. IEEE VTC Fall 2005*, vol.2, pp.1269–1273, Dallas, Texas, USA, Sept. 2005.
- [8] Q. Chen, K. Yamaguchi, X.P. Yang, and K. Sawaya, "Numerical analysis method for wireless channel of MIMO system," *Proc. PIMRC'04*, vol.4, pp.3008–3012, Barcelona, Spain, Sept. 2004.
- [9] X.P. Yang, K. Yamaguchi, Q. Chen, and K. Sawaya, "Numerical simulation for MIMO wireless channel by using hybrid method of FDTD and MoM," *Proc. ISAP'04*, vol.1, pp.313–316, Sendai, Japan, Aug. 2004.
- [10] K. Sawaya, "Antenna design by using method of moments," *IEICE Trans. Commun.*, vol.E88-B, no.5, pp.1766–1773, May 2005.
- [11] J.H. Richmond and N.H. Greay, "Mutual impedance of non-planar-skew sinusoidal dipoles," *IEEE Trans. Antennas Propag.*, vol.AP-23, no.3, pp.412–414, May 1975.