

変調プローブアレーを用いた電磁界の位相の測定法

水上 透[†] 陳 強[†] 澤谷 邦男[†]

[†] 東北大学大学院 工学研究科 電気・通信工学専攻 〒980-8579 仙台市青葉区荒巻字青葉 6-6-05

あらまし 変調プローブを用いた電磁界の測定では高速に全球面測定をすることが可能であり、また、天頂角方向に於いて同時に電磁界を測定することが可能である。しかし、これまでの測定対象は放射電磁界の振幅に限られており、電磁界の位相を測定することはできなかった。本報告では、変調信号とローカル信号を同時に測定し、それぞれの位相から RF 信号の位相を求める方法を提案し、その妥当性を検討する。

キーワード 位相測定, 電磁波測定, 放射効率, 変調, 測定装置

A Measurement Method Using a Modulated Probe Array for Phase of Electromagnetic Field

Toru MIZUKAMI[†], Qiang CHEN[†], and Kunio SAWAYA[†]

[†] Electrical and Communication Engineering, Graduate School of Engineering, Tohoku University
Aramaki Aza Aoba 6-6-05, Aoba-ku, Sendai, 980-8579, Japan

Abstract A simultaneous measurement method using a parallel modulated probe array was proposed to measure the electromagnetic radiation rapidly. The performance of the system using this method was demonstrated by the measurement time and some experimental results such as the radiation pattern and the antenna efficiency by our group. However, the phase measurement is not possible by using this system because of its structure. In this report, a phase measurement method using digital signal processing is proposed and some results of preliminarily experiments are demonstrated.

Key words Phase Measurement, EM Measurement, Radiation Efficiency, Modulation, Measurement Equipment

1. Introduction

The radiation pattern of antennas is usually measured by rotating the antenna under test (AUT) on a turntable. This conventional measurement requires several tens of seconds to several minutes depending on the speed of the rotation and the number of sampling points. Measurement of the radiation efficiency of antennas by integrating the radiation power on a closed surface including measured antennas [1], may take more than ten minutes when the mechanical turntable and spherical scanner are used. However, in practical antenna designing, it is strongly required to reduce the measurement time to measure the 3-D radiation pattern of antennas.

In the EMC (Electromagnetic Compatibility) research, it is required to measure the electromagnetic radiation which is instantaneous and irregular, such as the leaked electromagnetic radiation from the electric devices [2]. The radiated field should be measured simultaneously in several locations

around electric devices in order to estimate the source locations. Therefore, a method to measure the electromagnetic radiation simultaneously at several locations is necessary.

A measurement method using the modulated scattering technique (MST) has been proposed to measure the electromagnetic field rapidly [3]-[7]. The MST measurement employs array of the modulated scattering elements (MSEs) which are successively modulated by a low-frequency modulation signal. The electromagnetic field radiated by the AUT is received and modulated by the MSE. The modulated field is scattered by the MSE and is received by the AUT or by an auxiliary antenna to obtain the distribution of the incident electric field on each MSE. Since only a low frequency multiplexer and a power dividing network instead of expensive microwave switching networks are used to connect all the MSE, the MST measurement is a simple and economical method for measuring the electromagnetic field at a large number of observation points rapidly. The MST measure-

ment is actually a rapid measurement but not a simultaneous measurement, because the low-frequency modulation signal is successively scanned electrically over the MSE to distinguish the observation points.

A simultaneous measurement method using the parallel modulated probe array has been proposed by our research group [8]. Each modulated probe element is modulated by a low-frequency modulation signal with different frequencies. The modulated signal is combined and received by a broadband microwave receiver. The measurement accuracy has been evaluated by measurement of the radiation efficiency and the radiation pattern of antennas. Additionally, measurement of radiation efficiency of antenna located in the vicinity of head phantom has been performed by the present measurement system.

In this study, a phase measurement method using the modulated probe array is proposed and preliminary experiments are performed with two modulated probes at 2.5 GHz.

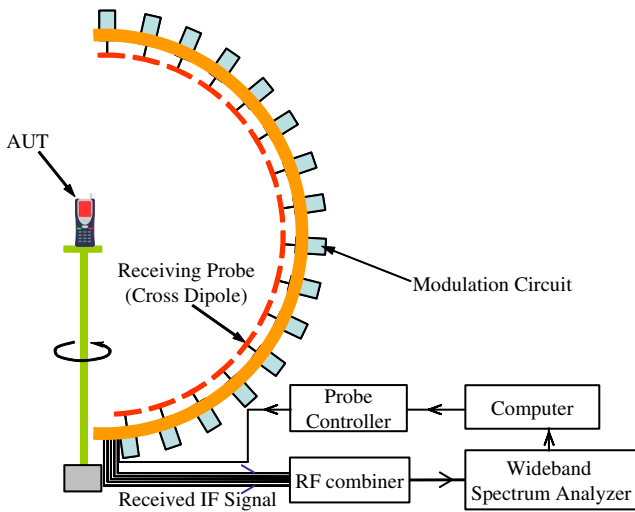

Fig. 1 Configuration of measurement system using parallel modulated probe array.

2. Measurement System Using Parallel Modulated Probe Array

2.1 Configuration

Fig. 1 shows the configuration of the measurement system using the parallel modulated probe array. The probe array consisting of 16 modulated probe elements is mounted on a semicircular arch with equal angular spacing from 0 to 168.75 degrees in zenith angle. The probe array together with an azimuth turntable makes the system possible to measure the radiation field on a spherical surface including the AUT located on the turntable. The modulation probe is composed of a cross dipole antenna and a shielding box which contains modulation circuits. Each probe has a crystal generating a local signal with individual frequency from 20 MHz to 40

MHz for modulating the received RF signal. The modulated signals with different frequencies are combined by RF combiners and delivered to a wideband spectrum analyzer. The polarization of the modulated probe array can be switched electrically. The measurement system is located inside the microwave anechoic chamber. The manufactured measurement system is shown in Fig. 2. The cross dipole antenna is shown in Fig. 3. $|S_{21}|$ between the horizontal antenna and the vertical antenna is less than -30 dB. The shielding box of each modulated probe includes electric circuits for modulation and amplification. The equivalent gain of the modulated probe is 10 dBi at 1 GHz.

Fig. 4 shows the spectrum of the received IF signal observed by a wide bandwidth spectrum analyzer. 16 peaks of the spectrum correspond to the RF signal level received by the 16 modulated probes when the RF frequency is 1 GHz. Specifications of the measurement system is shown in Table 1.

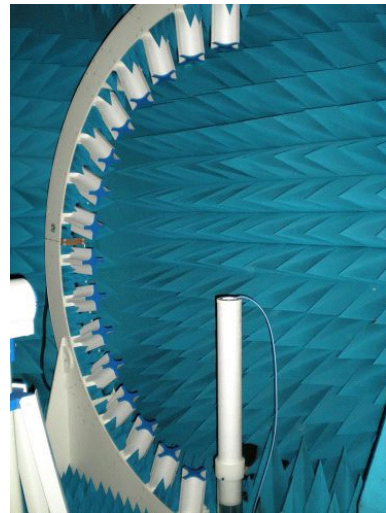

Fig. 2 Photo of measurement system using parallel modulated probe array.



Fig. 3 Photo of a modulated probe element.

The radiation efficiency of antennas is one of the important properties of antennas, especially antenna located in the vicinity of human body. The radiation efficiency can be also measured by this measurement system because this system

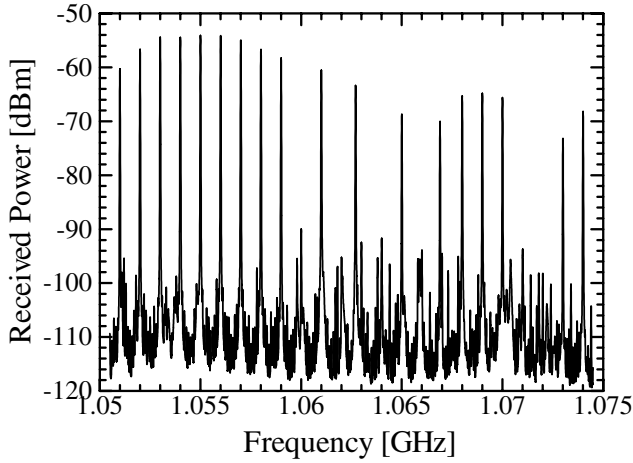

Fig. 4 Spectrum of received IF signal.

can measure total radiation power. When the loss of the antenna conductor is negligible, the input power is partly radiated outside and the remaining part is absorbed by the human body. The total radiated power can be obtained by integrating the radiated power over a spherical surface enclosing the antenna and human body [9]. The radiated power from the source antenna can be received by the modulated probes on the spherical surface which encloses AUT. The total radiated power P_r of the antenna can be calculated by pattern integration method as

$$P_{\text{rad}} = \frac{r^2}{A_e} \int_0^{2\pi} \int_0^\pi (P_\theta + P_\phi) \sin \theta d\theta d\phi \quad (1)$$

where P_θ and P_ϕ indicate the vertically and horizontally polarized components of the received power, respectively, A_e is the effective aperture area of the modulated probe, and r is the radius of the scanning surface. The radiation efficiency can be given by the ratio of radiated power and incident power as

$$\eta = \frac{P_{\text{rad}}}{P_{\text{inc}}} \quad (2)$$

where η , P_{rad} and P_{inc} indicate radiation efficiency, radiated power and incident power into AUT, respectively. In the measurement of radiation efficiency, radiated power from standard antenna is regarded as incident power into AUT.

Table 1 Specifications of the measurement system.

Radius of semicircular arch	1.03 m
Frequency range	0.8 ~ 2.5 GHz
Frequency step of local frequency	> 2 MHz
Measurement time for spherical scan	16 sec.
Repeatability of measurement	< 0.3 dB
$ S_{21} $ between horizontal antenna and vertical antenna	< 30 dB

2.2 Measurement Accuracy

Evaluation of measurement accuracy was performed by measuring the radiation pattern of a monopole antenna and radiation efficiency of the monopole antenna located in the vicinity of saline water at 1 GHz. The geometry of the monopole antenna as AUT is shown in Fig. 5, where the length of monopole is 7 cm and the size of the ground plane is 30 cm \times 30 cm. E -plane radiation pattern of the monopole antenna is measured and compared with the numerical analysis by FDTD (Finite Difference Time Domain) method in Fig. 6. Good agreement between measured and numerical data is obtained.

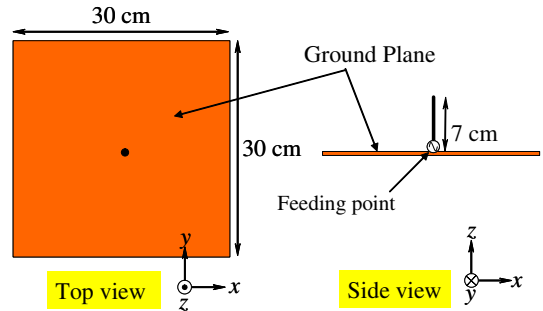

Fig. 5 Monopole antenna for performance evaluation.

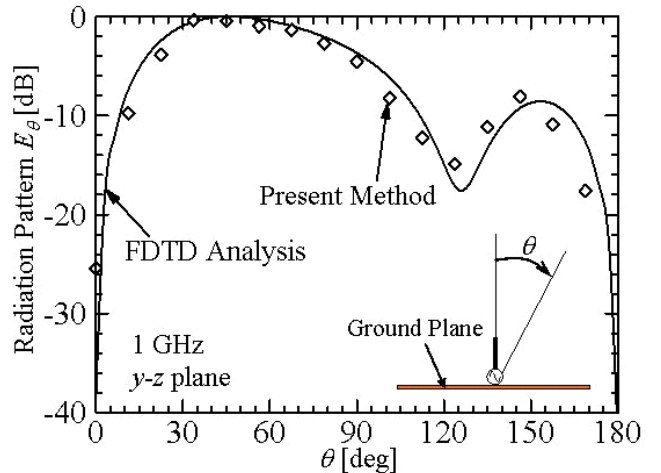

Fig. 6 Radiation pattern of the monopole antenna.

Fig. 7 shows a 3-D radiation pattern of a dipole antenna. Rapid measurement is one of the main advantages of the present measurement system. The radiation efficiency of a monopole antenna located in the vicinity of a plastic box filled with a 1.0 % salt solution was also measured. FDTD analysis is also performed for comparison, where the dielectric parameters of $\epsilon_r = 74.8$ and $\sigma = 1.90$ S/m are assumed for the 1.0 % salt solution. The complex permittivity of salt solution is given by

$$K = \epsilon_\infty + \frac{\epsilon_0 - \epsilon_\infty}{1 + j2\pi\tau f} - j \frac{\sigma}{2\pi\epsilon_0^* f} \quad (3)$$

where ϵ_0 , ϵ_∞ and ϵ_0^* are the static, high frequency and vacuum permittivities, respectively. τ is the relaxation time and σ indicates ionic conductivity of the dissolved salts. [10].

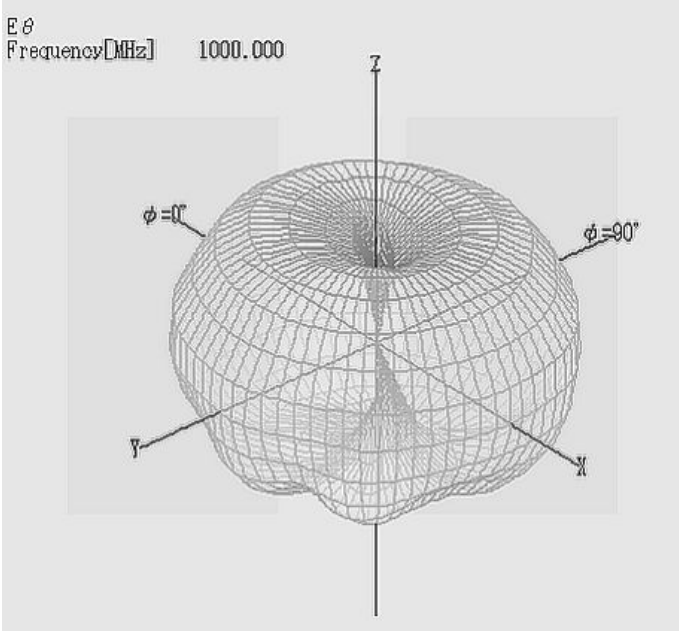

Fig. 7 3-D radiation pattern of half-wavelength dipole antenna.

The measured and calculated radiation efficiency versus the distance between the antenna and the surface of the box is shown in Fig. 8. Good agreement between the measurement and numerical analysis is obtained. According to the experimental results, high accuracy of measurement system is demonstrated. It should be noted that the required time to measure the 3-D radiation pattern and to obtain the radiation efficiency is only 16 seconds, which is much less than the time required by the conventional scanning probe.

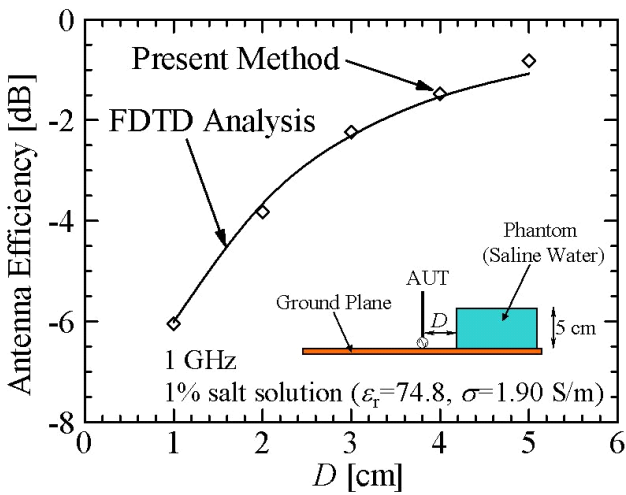

Fig. 8 Radiation efficiency of the monopole antenna located in the vicinity of the rectangular phantom.

3. Measurement of Radiation Efficiency of an Antenna Located in the Vicinity of Human Head Phantom

The evaluation of the power absorption by the human body is important not only for the potential hazard problem from the viewpoint of the electromagnetic compatibility, but also for the research and design of the antennas for mobile handsets, since these antennas are usually used near the human body and the absorption by the human body could decrease the radiation efficiency.

Fig. 9 shows the model of a handset and a monopole antenna located near the left ear of SAM (Specific Anthropomorphic Mannequin) phantom which is defined as the head model for SAR testing by the IEEE Standards Coordinating Committee 34. Distance between the antenna and surface of the phantom is D . The measurement was performed at 2 GHz. Sugar based solution is used as the phantom solution and the relative permittivity and conductivity of the phantom are $\epsilon_r = 32.60$ and $\sigma = 1.933$ S/m at 2 GHz, respectively. Although the dielectric constant of the phantom solution differs from the standards for compliance SAR testing (e.g., CENELEC EN50361, IEEE P1528, etc.), it was used for the measurement of the radiation efficiency, which is not affected dielectric constant significantly. Fig. 10 shows the measured efficiency as a function of the distance D .

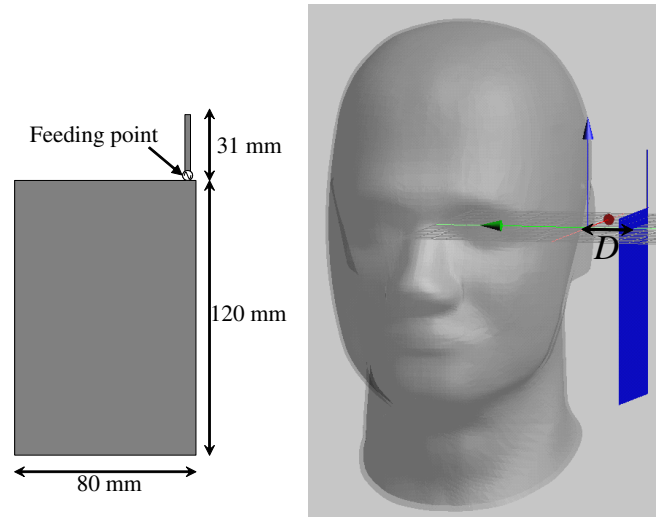

Fig. 9 Monopole antenna mounted on handset model and SAM.

Table 2 Specification of self-produced phantom solution.

	900 MHz		2 GHz	
	Expt.	IEEE Standard	Expt.	IEEE Standard
ϵ_r	40.77	41.5	32.60	40.0
σ [S/m]	0.930	0.97	1.933	1.4

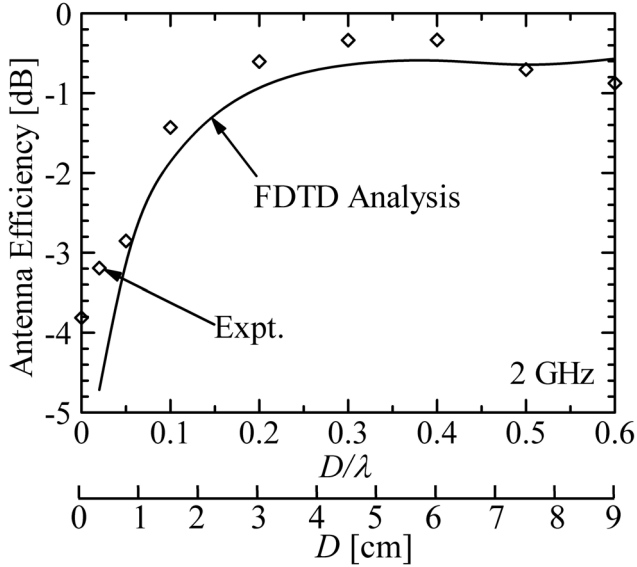

Fig. 10 Measured radiation efficiency of monopole antenna located in the vicinity of human phantom.

4. Phase Measurement

4.1 Measurement Method

Phase measurement is not possible by the measurement system using parallel modulated probe array because phase difference of IF signals are time-varying due to the fact that each LO signal has individual frequency. The phases of each LO signal can not be synchronized each other. Therefore, digital signal processing for canceling the phase components of the LO signal from the measured IF signal is required.

Preliminarily experiments for a phase measurement method using digital signal processing with two modulated probe elements were performed by a measurement system shown in Fig. 11. The RF signal radiated by a standard dipole antenna is received by two modulated probe elements at each point. Both modulated probe elements are modulated simultaneously by low-frequency LO signals with different frequencies. Then, the received RF signal and LO signal are mixed on a silicon Schottky diode loaded on the each modulated probe element. The IF signals are combined by a power combiner. The IF signal is measured by a real-time spectrum analyzer after down-converting. Despite the receiving frequency band-width can be set up less than 20 MHz on the real-time spectrum analyzer, the measured IF signal has LO signal components and IF signal components because of the down-converting. The phases of the each digitized complex LO signal components and IF signal components are obtained by FFT (Fast Fourier Transformation). The phase difference is given by

$$\theta_{RF1} = \theta_{IF1} - \theta_{LO1} \quad (4)$$

$$\theta_{RF2} = \theta_{IF2} - \theta_{LO2} \quad (5)$$

$$\Delta\theta_{RF} = \theta_{RF1} - \theta_{RF2} \quad (6)$$

where $\Delta\theta_{RF}$, θ_{RF1} , θ_{RF2} , θ_{IF1} , θ_{IF2} , θ_{LO1} , and θ_{LO2} indicate phase difference of RF signals of each receiving point, phase of RF signal #1, RF signal #2, IF signal #1, IF signal #2, LO signal #1 and LO signal #2, respectively. Despite these phases are relative values, the phase difference between the RF signals of each receiving point is time-invariant when both IF signal components and both LO signal components are measured simultaneously and are substituted into eqs. (4)-(6).

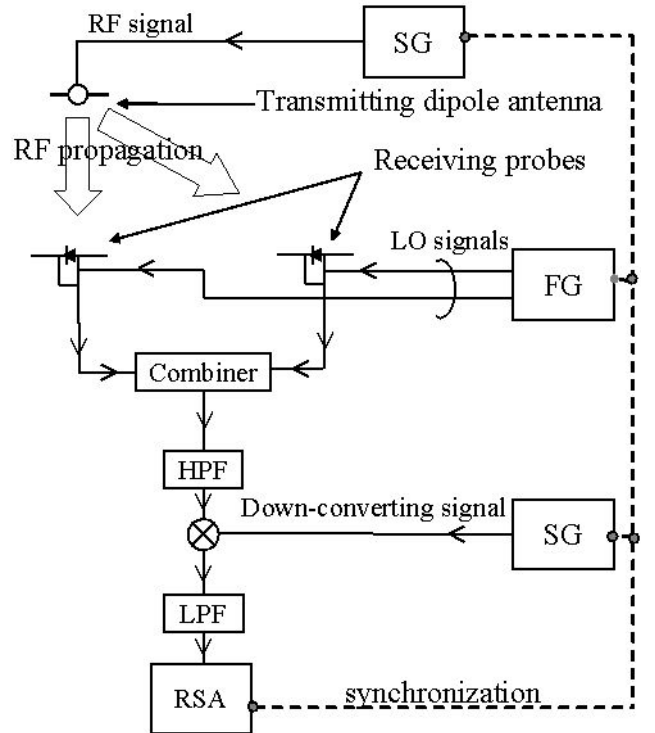

Fig. 11 Phase measurement system.

4.2 Measurement Results

The phase difference between the two modulated probe elements was measured with changing difference of propagation distance between the RF signals which were received by each modulated probe element at 2.5 GHz. The specifications of the preliminarily experiments are shown in Table 3. A standard dipole antenna and the modulated probe elements are located in an anechoic chamber and directly aligned as Fig. 12. The modulated probe element #1 (MP1) is located from 158.1 cm from the standard dipole antenna and the modulated probe element #2 (MP2) is located in the opposite side of the standard dipole antenna from the MP1. In this measurement, the distance between the MP1 and MP2 is changed by moving the position of the MP2.

The spectrum of measured IF signal is shown in Fig.

Table 3 Specifications of phase measurement.

Frequency of RF signal	2.5 GHz
Amplitude of RF signal	0 dBm
Frequency of LO signal	9.99, 10.005 MHz
Input voltage of LO signal	$V_{p-p} = 3$ V
Frequency of down-converting signal	2.499975 GHz
Amplitude of down-converting signal	0 dBm
Center frequency of receiving span	10.01 MHz
Receiving bandwidth	50 kHz
Num. of sampling points	1024
Aquisition time	12.7875 sec.

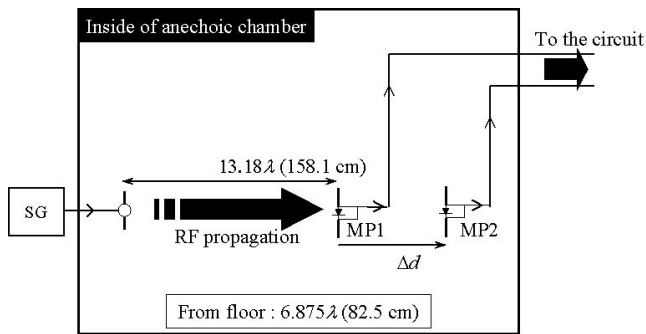

Fig. 12 Configuration of measurement systems of preliminary experiments.

13. The frequency components of LO signals and down-converted IF signals are obtained in sufficient intensity as compared with noise level. The measured phase difference is shown in Fig. 14. It is shown that the validity of the proposed phase measuring system is confirmed by the comparison of the measured phase difference and theoretical value.

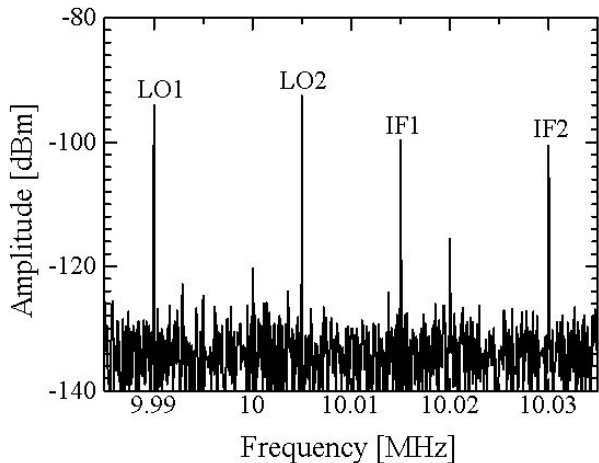

Fig. 13 Spectrum of measured IF signal.

5. Summary

A simultaneous measurement method using the parallel modulation technique has been proposed. The measurement of radiation efficiency can be performed within only about 16

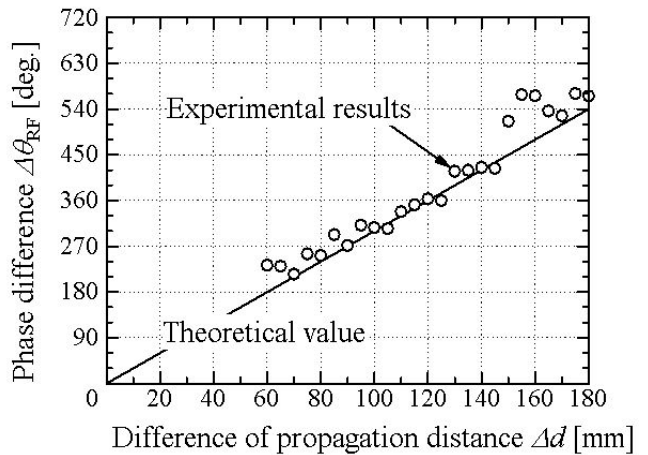

Fig. 14 Measured phase difference of RF signals received by two modulated probe elements.

seconds with high accuracy due to use of the parallel modulated probe array. In the case of the model including human phantom, the radiation efficiency also can be measured easily. However, phase measurement is not possible by using this method and phase measurement method using digital signal processing was proposed. The phase measurement with two modulated probe elements was also performed. According to the results, validity of phase measurement has been demonstrated.

Acknowledgment

The authors are thankful to Device Co., LTD. for technical assistance to manufacture the measurement system using modulated probe array.

This research was partly supported by Telecom Engineering Center (TELEC).

Reference

- [1] Qiang Chen, Takayuki Shinohe, Kazuhisa Igari, and Kunio Sawaya, "Measurement of Radiation Efficiency of Antennas in the Vicinity of Human Model," *IEICE Trans. Communications*, Vol. E80-B, No. 5, pp. 709-711, May 1997.
- [2] Rahmat-Samii, Y. Williams, L.I. Yaccarino, R.G., "The UCLA bi-polar planar-near-field antenna-measurement and diagnostics range," *IEEE Antennas and Propagation Magazine*, vol. 37, No. 6, pp. 16-35, 1995.
- [3] J.-C. Bolomey, B.J. Cown, G. Fine, L. Jofre, M. Mostafavi, D. Picard, J.P. Estrada, P.G. Friederich, and F.L. Cain, "Rapid near-field antenna testing via arrays of modulated scattering probes," *IEEE Trans. Antennas Propagat.*, vol. 36, No. 6, pp. 804-814, June 1988.
- [4] P.O. Iversen, Ph. Garreau, K. Englund, E. Pasalic, O. Edvardsson, G. Engblom, "Real-Time Spherical Near-Field Antenna Test Facility for Personal Communications Applications," *IEEE AP2000 Conference*, April 2001.
- [5] D. Serafin, et al., "Spherical Near-Field Facility for Microwave Coupling Assessments in the 100 MHz - 6 GHz Frequency Range," *IEEE Trans. Electromagn Compat.*, Vol. 40, No. 3, pp. 225-233, Aug. 1998.
- [6] Q. Chen and K. Sawaya, "Modulated Scattering Technique Based Method for Measuring Electromagnetic Field Simul-

- taneously,” *Proc. KJJC*, 2004.
- [7] Q. Chen, T. Watanabe, and K. Sawaya, “Simultaneous Measurement of Radiation Pattern by Modulated Scattering Element Array,” *Proceedings of MAPE 2005*, pp. 366-369, August 2005.
 - [8] Q. Chen, K. Sawaya, T. Habu, and R. Hasumi, “Simultaneous Electromagnetic Measurement using a parallel modulated Probe Array,” *IEEE Trans. Antenas and Propagat.*, Vol. 49, No. 2, pp. 263-269, 2007.
 - [9] T. Maeda and T. Morooka, “Radiation Efficiency Measurement for Small Antennas Using a New Radiation Characteristic Measurement Equipment,” in *Proceedings of ISAP '89*, 4B2-2. 1989.
 - [10] A. Stogry, “Equations for calculating the dielectric constant of saline water,” in *IEEE Trans. Microwave Theory Techn.*, Vol. MTT-19, pp. 733-736, Aug. 1971.